



KEMENTERIAN PENDIDIKAN MALAYSIA
JABATAN PENDIDIKAN NEGERI SARAWAK

PROGRAM SEMARAK KASIH SPM 2.0 JPN SARAWAK TAHUN 2021

FIZIK

KERTAS 1

SET 2

**PROGRAM
SEMARAK KASIH SPM 2.0
TAHUN 2021**

JABATAN PENDIDIKAN NEGERI SARAWAK

**FIZIK
(4531/1)**

**PRAKTIS KERTAS 1
SET 2**

Pengenalan

Program Semarak Kasih yang dilaksanakan pada tahun 2020 telah mendapat sambutan yang menggalakkan daripada warga pendidik dan murid, khususnya calon SPM 2020. Sehubungan dengan itu, pada tahun 2021 ini, Sektor Pembelajaran, Jabatan Pendidikan Negeri Sarawak mengadakan **Program Semarak Kasih SPM 2.0** untuk membantu guru dan calon SPM menghadapi peperiksaan SPM 2021.

Modul yang dihasilkan disertakan dengan sampel Jadual Spesifikasi Ujian (JSU) dan sampel item/soalan mengikut format baharu peperiksaan SPM mulai 2021 untuk dijadikan bahan panduan dan rujukan guru-guru dan juga sebagai bahan latihan/ulangkaji kepada calon-calon SPM 2021 di semua sekolah menengah di negeri Sarawak.

OBJEKTIF PROGRAM

1. Memastikan calon SPM menguasai format baharu Peperiksaan SPM 2021.
2. Memastikan calon SPM mempunyai bahan pembelajaran yang berfokus ke arah peperiksaan SPM.
3. Meningkatkan pencapaian akademik calon SPM 2021.
4. Melonjakkan keputusan SPM 2021 Negeri Sarawak

Senarai Kandungan

Bil.	Perkara	Muka surat
1	Format Kertas Peperiksaan SPM Mulai Tahun 2021	2
2	Latihan - Praktis Fizik 4531/1: Set 2	3 – 22
3	Skema Jawapan/Pemarkahan	23
4	LAMPIRAN: Sampel Jadual Spesifikasi Ujian (JSU) untuk Praktis Fizik 4531/1: Set 2	24

Senarai Ahli Panel Pembina Modul Semarak Kasih SPM 2.0

Bil.	Nama Guru	Sekolah	PPD
1.	Nafri bin Razali (Ketua)	SMK Green Road	PPD Kuching
2.	Esmawaty binti Samad	SMK Trusan	PPD Lawas
3.	Noor Hidayah binti Rasdi	SMK Riam	PPD Miri
4.	Tan Sze Ning	SMK Tun Abang Haji Openg	PPD Kuching
5.	Sia Chee Kai	SMK Sungai Merah	PPD Sibul
6.	Iswandi bin Jamain	SMK Beladin	PPD Betong
7.	Sia Dng Kee	Kolej Tun Datu Tuanku Haji Bujang	PPD Miri
8.	Ho Xin Jing	SMK Spaoh	PPD Betong
9.	Tan Hui Lee	SMK Padungan	PPD Kuching
10.	Faizzatul Najwa binti Noor Azmin	SMK Agama Limbang	PPD Limbang
11.	Ng Chid Sia	SMK Batu Kawa	PPD Padawan

Penyelaras

Bil.	Nama Pegawai	Stesen Bertugas
1	Evelin anak Medong	Unit Sains dan Matematik, JPN Sarawak

**FORMAT INSTRUMEN PEPERIKSAAN SPM MULAI TAHUN 2021
BAGI MATA PELAJARAN FIZIK (KOD: 4531)**

BIL	PERKARA	KERTAS 1 (4531/1)	KERTAS 2 (4531/2)	KERTAS 3 (4531/3)
1	Jenis Instrumen	Ujian Bertulis		Ujian Amali
2	Jenis Item	Objektif Aneka Pilihan	<ul style="list-style-type: none"> • Subjektif Berstruktur • Subjektif Respons Terhad • Subjektif Respons Terbuka 	Subjektif Berstruktur
3	Bilangan Soalan	40 soalan (40 markah) (Jawab semua soalan)	Bahagian A: <ul style="list-style-type: none"> • 8 soalan (60 Markah) (Jawab semua soalan) Bahagian B: (20 Markah) <ul style="list-style-type: none"> • 2 soalan (Jawab 1 soalan) Bahagian C: (20 Markah) <ul style="list-style-type: none"> • 1 soalan 	3 item (Jawab mengikut subjek yang didaftar)
4	Jumlah Markah	40 markah	100 markah	15 markah bagi setiap item
5	Konstruk	<ul style="list-style-type: none"> • Mengingat • Memahami • Mengaplikasi • Menganalisis 	<ul style="list-style-type: none"> • Mengingat • Memahami • Mengaplikasi • Menganalisis • Menilai • Mencipta 	Kemahiran proses sains
6	Tempoh Ujian	1 jam 15 minit	2 jam 30 minit	40 minit + 5 minit setiap item (5 minit: sesi merancang) (40 minit: masa menjawab soalan)
7	Cakupan Konteks	Standard kandungan dan standard pembelajaran dalam Dokumen Standard Kurikulum dan Pentaksiran (DSKP) KSSM (Tingkatan 4 dan 5)		
8	Aras Kesukaran	Rendah : Sederhana : Tinggi 5 : 3 : 2		
9	Kaedah Penskoran	Dikotomus	Analitikal	
10	Alat Tambahan	Kalkulator saintifik		

PRAKTIS FIZIK 4531/1
SET 2

1. Pecutan boleh diungkapkan dalam sebutan
Acceleration can be expressed in terms of

A. $\frac{\text{Panjang}}{\text{Masa}} // \frac{\text{Length}}{\text{Time}}$

B. $\frac{\text{Panjang}}{\text{Masa} \times \text{Masa}} // \frac{\text{Length}}{\text{Time} \times \text{Time}}$

C. $\frac{\text{Jisim}}{\text{Panjang} \times \text{Panjang} \times \text{Panjang}} // \frac{\text{Mass}}{\text{Length} \times \text{Length} \times \text{Length}}$

D. $\frac{\text{Jisim} \times \text{Panjang}}{\text{Masa}} // \frac{\text{Mass} \times \text{Length}}{\text{Time}}$

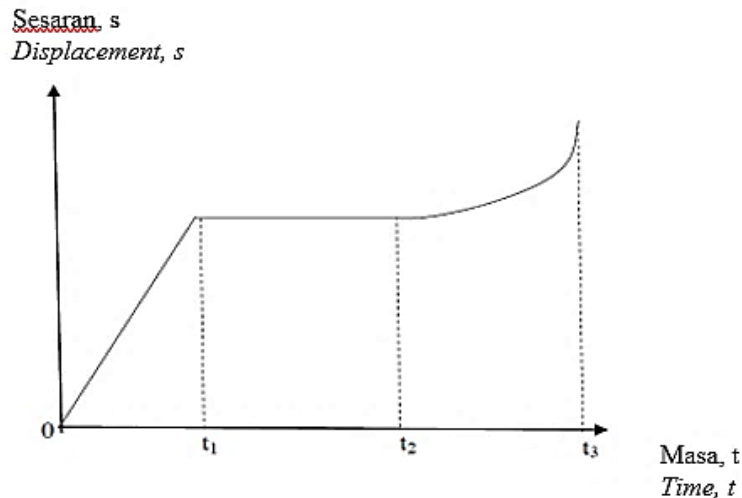

2.

Rajah 1 / *Diagram 1*

Rajah 1 menunjukkan graf sesaran, s melawan masa, t yang mewakili gerakan suatu objek.

Antara berikut, yang manakah pernyataan yang **benar**?

Diagram 1 shows displacement, s against time, t graph that represents the motion of an object.

*Which of the following statements is **correct**?*

- A Objek bergerak dengan pecutan seragam untuk t_1 saat pertama.
The object moves with uniform acceleration for the first t_1 second.
- B Objek berhenti antara t_1 dan t_2 .
The object stops between t_1 and t_2 .
- C Luas di bawah graf mewakili halaju objek.
The area under the graph represents the velocity of the object
- D Kecerunan graf mewakili kadar perubahan halaju objek.
The gradient of the graph represents the rate of change of the velocity of the object.

3. Sehelai tisu dan sekeping duit syiling dibiarkan jatuh dari ketinggian tertentu dalam vakum. Antara kuantiti yang berikut, yang manakah tidak berubah?
*A piece of tissue paper and a coin are released from a certain height in vacuum.
Which of the following quantities does not change?*

- A Sesaran
Displacement
- B Halaju
Velocity
- C Pecutan
Acceleration

4. Rajah 2 menunjukkan sos cili di dalam botol mudah dituangkan jika botol itu digerakkan dengan laju ke bawah dan dihentikan dengan tiba-tiba.
Diagram 2 shows a chili sauce in the bottle can be easily poured out if the bottle is moved down fast with a sudden stop.



Rajah 2 / *Diagram 2*

Situasi ini boleh diterangkan oleh
The situation can be explained by

- A Hukum gerakan Newton pertama
Newton's first law of motion
- B Hukum gerakan Newton kedua
Newton's second law of motion
- C Hukum gerakan Newton ketiga
Newton's third law of motion
- D Prinsip Keabadian Momentum
Principle of Conservation of Momentum

5. Rajah 3 menunjukkan sebutir peluru ditembak dari sepucuk senapang.
Diagram 3 shows a bullet is fired from a rifle.



Rajah 3 / Diagram 3

Apakah yang berlaku kepada momentum peluru dan senapang sebelum dan selepas tembakan?
What happen to the momentum of the bullet and the rifle before and after the bullet is fired?

- A Jumlah momentum sebelum tembakan = Jumlah momentum selepas tembakan
Total momentum before the bullet is fired = Total momentum after the bullet is fired
- B Jumlah momentum sebelum tembakan > Jumlah momentum selepas tembakan
Total momentum before the bullet is fired > Total momentum after the bullet is fired
- C Jumlah momentum sebelum tembakan < Jumlah momentum selepas tembakan
Total momentum before the bullet is fired < Total momentum after the bullet is fired
- D Selepas tembakan, magnitud momentum peluru > magnitud momentum senapang
After the bullet is fired, the magnitude of the momentum of the bullet > the magnitude of the momentum of the rifle
6. Sebiji bola keranjang berjisim 0.6 kg dibaling secara mengufuk pada kelajuan seragam 10 m s^{-1} menghentam dinding berlapis span. Tanpa melantun, ia jatuh ke lantai.
Jika daya yang bertindak pada dinding tersebut ialah 12.5 N, berapakah masa perlanggaran?
A basketball of mass 0.6 kg is thrown horizontally at uniform speed of 10 m s^{-1} hitting a sponge padded wall. Without rebound, it falls to the floor.
If the force acting on the wall is 12.5 N, what is the time of impact?
- A 0.5 s
- B 0.8 s
- C 2.0 s
- D 6.0 s
7. Sebuah satelit penyelidikan perlu mengorbit pada jarak $6.77 \times 10^6 \text{ m}$ daripada pusat bumi untuk mengambil imej yang jelas pada permukaan bumi. Hitung tempoh orbit satelit tersebut. (Jejari orbit bulan = $3.83 \times 10^8 \text{ m}$, tempoh orbit bulan = 655.2 jam)
A research satellite needs to orbit at a distance of $6.77 \times 10^6 \text{ m}$ from the centre of the earth to capture clear images of the surface of the earth. Calculate the orbital period of the satellite.
(Radius of the orbit of the moon = $3.83 \times 10^8 \text{ m}$, orbital period of the moon = 655.2 hours)
- A 11.54 jam
11.54 hours
- B 3.40 jam
3.40 hours
- C 1.77 jam
1.77 hours
- D 1.54 jam
1.54 hours

8.

Planet	Jisim, M / kg <i>Mass, M / kg</i>	Jejari, R / m <i>Radius, R / m</i>
Zuhrah <i>Venus</i>	4.87×10^{24}	6.05×10^6
Musytari <i>Jupiter</i>	1.90×10^{27}	6.99×10^7

Jadual 1 / Table 1

Jadual 1 menunjukkan maklumat berkaitan dua buah planet, Zuhrah dan Musytari.

Berdasarkan maklumat yang diberi, pilih pernyataan yang **benar**.

Table 1 shows an information of two planets, Venus and Jupiter.

*Based on the information given, choose the **correct** statement.*

- A Halaju lepas dari permukaan Musytari adalah sama dengan halaju lepas dari permukaan Zuhrah.
The escape velocity from the surface of Jupiter is the same as the escape velocity from the surface of Venus.
- B Halaju lepas dari permukaan Musytari lebih rendah daripada halaju lepas dari permukaan Zuhrah.
The escape velocity from the surface of Jupiter is lower than the escape velocity from the surface of Venus.
- C Halaju lepas dari permukaan Musytari lebih tinggi daripada halaju lepas dari permukaan Zuhrah.
The escape velocity from the surface of Jupiter is higher than the escape velocity from the surface of Venus.
- D Halaju lepas hanya bergantung kepada jejari planet.
The escape velocity only depends on the radius of the planet.

9. Rajah 4 menunjukkan seorang budak lelaki yang mengalami demam panas. Ibunya menampalkan pek sejuk ke atas dahinya.
Diagram 4 shows a boy who is having a high fever. His mother patches a cold pack on his forehead.



Rajah 4 / Diagram 4

Pernyataan berikut yang manakah **betul** apabila budak lelaki itu dan pek sejuk berada dalam keseimbangan terma?

*Which of the following statements is **correct** when the boy and the cold pack are at thermal equilibrium?*

- A Kuantiti haba budak lelaki sama dengan pek sejuk
The quantity of heat in the boy is the same as in the cold pack
- B Kadar bersih pengaliran haba antara budak lelaki dan pek sejuk adalah sifar
Net rate of heat flow between the boy and the cold pack is zero
- C Suhu pek sejuk adalah lebih tinggi dari budak lelaki itu
The temperature of the cold pack is higher than the boy
- D Tiada pengaliran haba antara budak lelaki dan pek sejuk
There is no heat flow between the boy and the cold pack
10. Rajah 5 menunjukkan perubahan keadaan dan suhu bagi 1 kg ais.
Diagram 5 shows the changes of state and temperature of 1 kg ice.

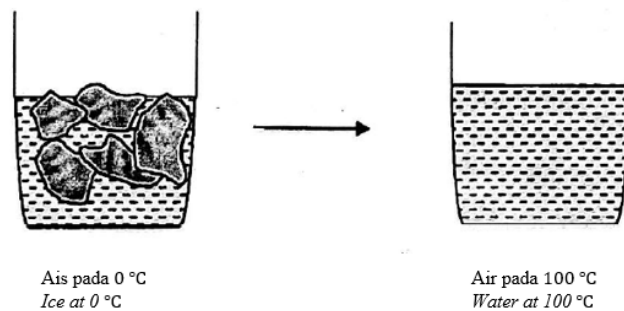

Rajah 5 / Diagram 5

Berapakah jumlah haba yang diserap?

[Muatan haba tentu air = $4200 \text{ J kg}^{-1}\text{°C}^{-1}$, haba pendam tentu ais = $336\,000 \text{ J kg}^{-1}\text{°C}^{-1}$]

What is the total heat absorbed?

[Specific heat capacity of water = $4200 \text{ J kg}^{-1}\text{°C}^{-1}$, specific latent heat of fusion = $336\,000 \text{ J kg}^{-1}\text{°C}^{-1}$]

- A 4 200 J
 B 336 000 J
 C 420 000 J
 D 756 000 J

11. Hukum Charles menyatakan bahawa apabila tekanan suatu gas adalah malar, isipadu gas adalah berkadar terus dengan suhu mutlaknya untuk suatu gas berjisim tetap.
Graf manakah yang mewakili hubungan antara isipadu, V dengan suhu mutlaknya, T ?
Charles' Law states that when the pressure of a gas is kept constant, the volume of the gas is directly proportional to its absolute temperature for a fixed mass gas.
Which graph represents relationship between volume, V and absolute temperature, T ?

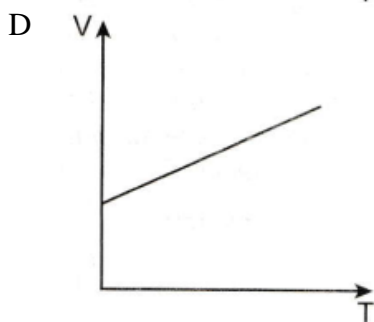
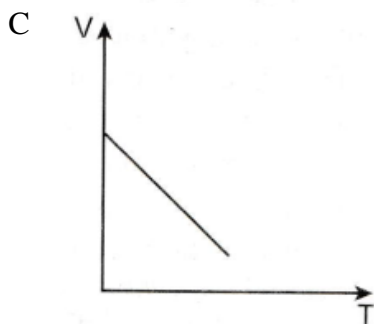
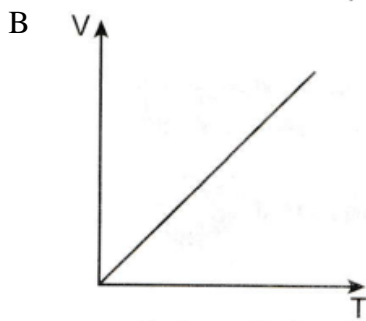
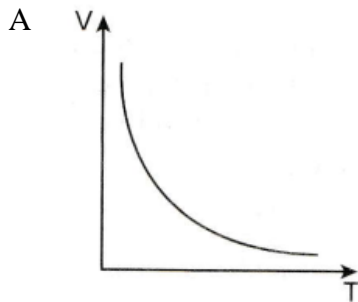

12. Rajah 6 menunjukkan corak muka gelombang yang dihasilkan oleh penggetar dalam tangki riak.
Diagram 6 shows the pattern of wavefronts produced by a vibrator in a ripple tank.

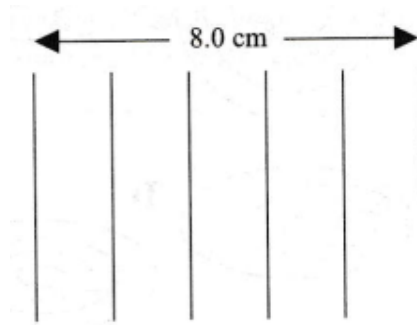

Rajah 6 / Diagram 6

Jika gelombang merambat dengan kelajuan 40 cm s^{-1} , hitungkan frekuensi bagi penggetar.
If the waves are propagated with a speed of 40 cm s^{-1} , calculate the frequency of the vibrator.

- A 1.6 Hz
B 5 Hz
C 10 Hz
D 25 Hz
13. Satu sistem dengan resonans berayun pada _____ yang maksimum.
The resonating system oscillate at its maximum _____.
- A frekuensi
frequency
B panjang gelombang
wave length
C amplitud
amplitude
D laju
speed
14. Antara yang berikut, yang manakah menunjukkan hubungan antara sudut tuju, i dan sudut pantulan, r apabila bagi pantulan gelombang berlaku?
Which of the following shows the relationship between the angle of incidence, i and the angle of reflection, r when reflection of wave happens?
- A $i < r$
B $i > r$
C $i = 90^\circ$
D $i = r$

15. Antara fenomena gelombang berikut, yang manakah melibatkan perambatan gelombang air melalui satu celah yang sempit?
Which of the following phenomena of waves involved the propagation of water waves passing through a narrow gap?

- A Pantulan gelombang
Reflection of waves
- B Pembelauan gelombang
Diffraction of waves
- C Pembiasan gelombang
Refraction of waves
- D Interferens gelombang
Interference of waves

16. Rajah 7 menunjukkan corak pinggir yang diperoleh daripada satu eksperimen dwicelah Young. Jarak pemisahan antara dua celah ialah 0.2 mm dan jarak antara skrin dan plat dwicelah ialah 2.5 m.

Diagram 7 shows the patterns of interference fringes obtained from a Young's double slit experiment. The separation distance of the two slits is 0.2 mm and the distance between the screen and the double-slit plate is 2.5 m.

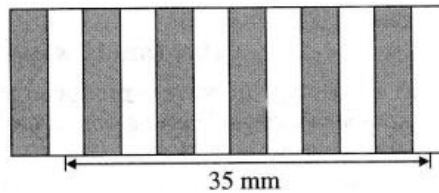

Rajah 7 / Diagram 7

Hitungkan panjang gelombang bagi cahaya yang digunakan dalam eksperimen.
Calculate the wavelength of light used in the experiment.

- A 5.6×10^{-7} m
 - B 4.7×10^{-7} m
 - C 2.8×10^{-7} m
 - D 2.8×10^{-6} m
17. Rajah 8 menunjukkan satu sinar cahaya merambat dari cecair Y ke udara. Sebahagian sinar cahaya itu dibiarkan sepanjang permukaan cecair, dan bakinya dipantulkan di dalam cecair.
Diagram 8 shows a light ray propagates from liquid Y to air. Part of its ray reflected along the surface of the liquid, and the rest is reflected inside the liquid.

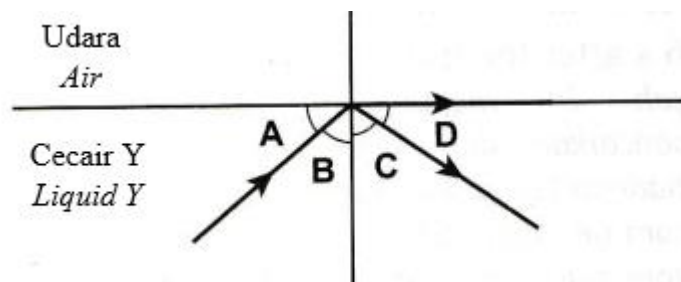

Rajah 8 / Diagram 8

Sudut manakah, A, B, C atau D, yang merupakan sudut genting bagi cecair Y?
Which angle, A, B, C or D, is the critical angle of liquid Y?

18. Antara graf-graf berikut, yang manakah berdasarkan formula kanta cembung nipis,
 $\frac{1}{f} = \frac{1}{u} + \frac{1}{v}$?

Which of the following graphs are based on a thin convex lens formula, $\frac{1}{f} = \frac{1}{u} + \frac{1}{v}$?

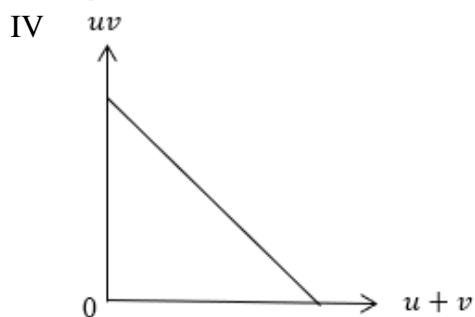
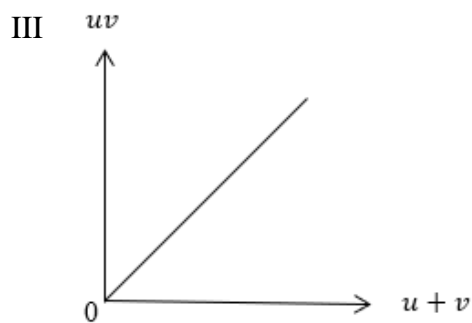
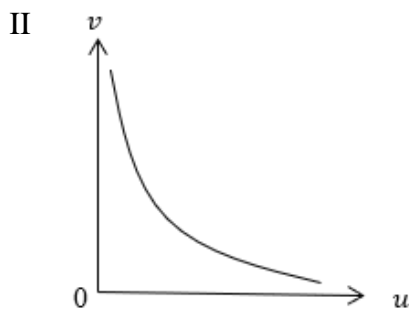
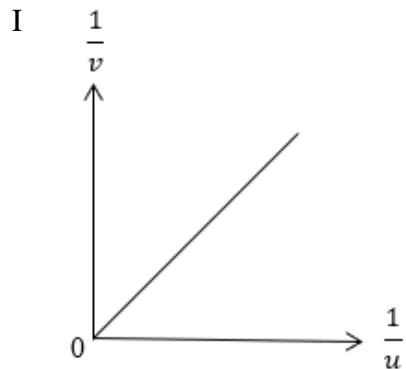

- A I dan II sahaja
I and II only
 B I dan III sahaja
I and III only
 C II dan III sahaja
II and III only
 D I, II, III dan IV
I, II, III and IV

19. Rajah 9 menunjukkan satu gambar rajah sinar sebuah mikroskop majmuk. f_o dan f_e masing-masing adalah panjang fokus kanta objek dan kanta mata. L ialah jarak di antara kanta objek dan kanta mata.

Diagram 9 shows the ray diagram of a compound microscope. f_o and f_e are the focal length of objective lens and eyepiece lens respectively. L is the distance between objective lens and eyepiece lens.

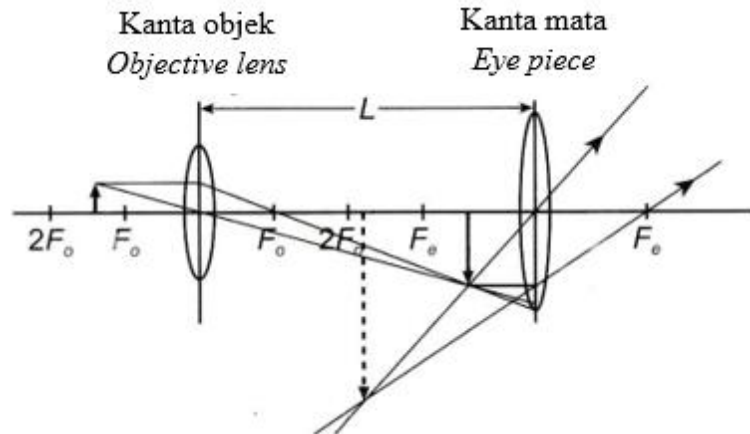

Rajah 9 / Diagram 9

Hubungan manakah yang **betul**?

*Which relationship is **correct**?*

- A $L < f_o + f_e$
 - B $L = f_o + f_e$
 - C $L > f_o + f_e$
 - D $L < f_o - f_e$
20. Rajah 10 menunjukkan objek yang terletak di hadapan cermin cekung. Jarak objek kurang dari panjang fokus, f , cermin.
- Diagram 10 shows an object located in front of a concave mirror. The object distance is less than the focal length, f , of the mirror.*

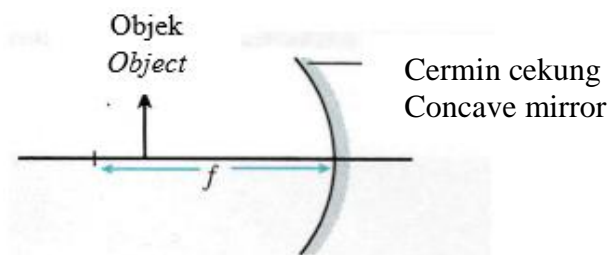

Rajah 10 / Diagram 10

Apakah ciri-ciri imej yang terbentuk?

What are the characteristics of the image formed?

- A Nyata, tegak, diperbesar
Real, upright, magnified
- B Nyata, songsang, diperkecil
Real, inverted, diminished
- C Maya, songsang, diperkecil
Virtual, inverted, diminished
- D Maya, tegak, diperbesar
Virtual, upright, magnified

21.



Rajah 11 / Diagram 11

Rajah 11 menunjukkan daya-daya yang bertindak pada sebuah kereta. Apakah jenis gerakan kereta itu?

Diagram 11 shows the forces acting on a car. What is the type of motion for the car?

- A Pegun
Stationary
- B Bergerak dengan halaju seragam
Moves with constant velocity
- C Bergerak dengan pecutan seragam
Moves with constant acceleration
- D Bergerak dengan pecutan sifar
Moves with zero acceleration

22.



Rajah 12 / Diagram 12

Rajah 12 menunjukkan seorang lelaki menolak mesin rumput dengan daya 90 N. Berapakah daya tolakan dalam arah mengufuk?

Diagram 12 shows a man pushing a lawn mower with a force of 90 N. What is the pushing force in the horizontal direction?

- A 45.0 N
- B 77.9 N
- C 90.0 N
- D 180.0 N

23. Suatu objek berada dalam keadaan keseimbangan daya apabila daya-daya yang bertindak ke atas objek tersebut

An object is said to be in equilibrium of forces when the forces acting on it

- A adalah pada arah yang sama.
are in same direction.
- B adalah pada arah yang bertentangan.
are in opposite direction.
- C menghasilkan daya paduan sifar.
produce a zero resultant force.
- D menghasilkan daya paduan lebih daripada sifar.
produce resultant force greater than zero.

24.

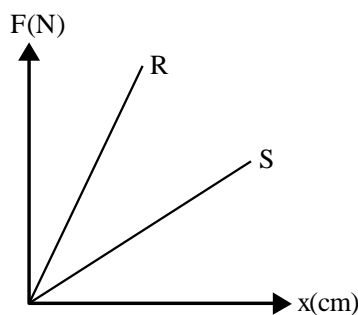

Rajah 13 / Diagram 13

Rajah 13 menunjukkan graf daya regangan, F melawan pemanjangan, x bagi spring R dan S. Kedua-dua spring adalah diperbuat daripada bahan yang sama dan mempunyai ketebalan yang sama. Pernyataan berikut yang manakah **benar** mengenai spring R dan spring S?

*Diagram 13 shows a graph of stretching force, F against extension, x of springs R and S. Both springs are made of same material and have the same thickness. Which of the following statement about spring R and spring S is **correct**?*

- A Spring S kurang keras berbanding spring R
Spring S is less stiff compared to spring R
- B Spring S mempunyai pemalar daya yang lebih besar daripada R
Spring S has a larger force constant than spring R
- C Spring S mempunyai diameter gelung yang lebih kecil daripada spring R
Spring S has a smaller coil diameter than spring R
- D Spring S mempunyai diameter dawai spring yang lebih besar daripada spring R
Spring S has a greater diameter of wire of spring than spring R

25.

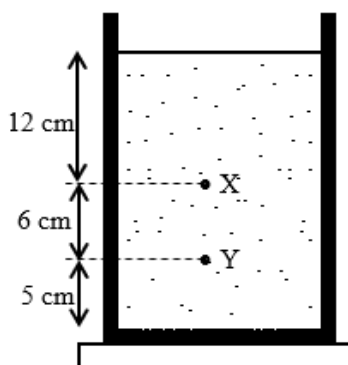

Rajah 14 / Diagram 14

Rajah 14 menunjukkan air di dalam sebuah bikar. Berapakah perbezaan tekanan air di antara titik X dan titik Y?

[Ketumpatan air, $\rho = 1\,000\text{ kg m}^{-3}$, pecutan graviti, $g = 9.81\text{ m s}^{-2}$]

Diagram 14 shows water in a beaker. What is the difference in water pressure between point X and point Y?

[Water density, $\rho = 1\,000\text{ kg m}^{-3}$, gravitational acceleration, $g = 9.81\text{ m s}^{-2}$]

- A 491 Pa
- B 589 Pa
- C 1 177 Pa
- D 1 766 Pa

26.

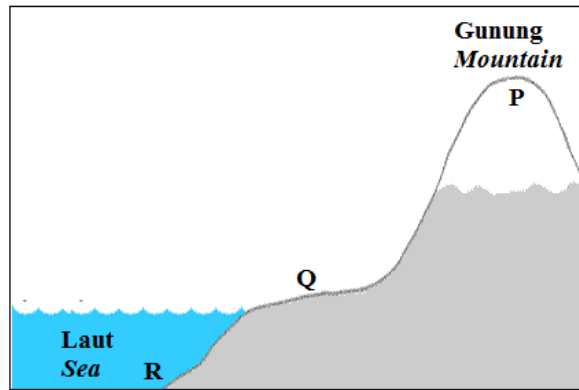

Rajah 15(a) / Diagram 15(a)

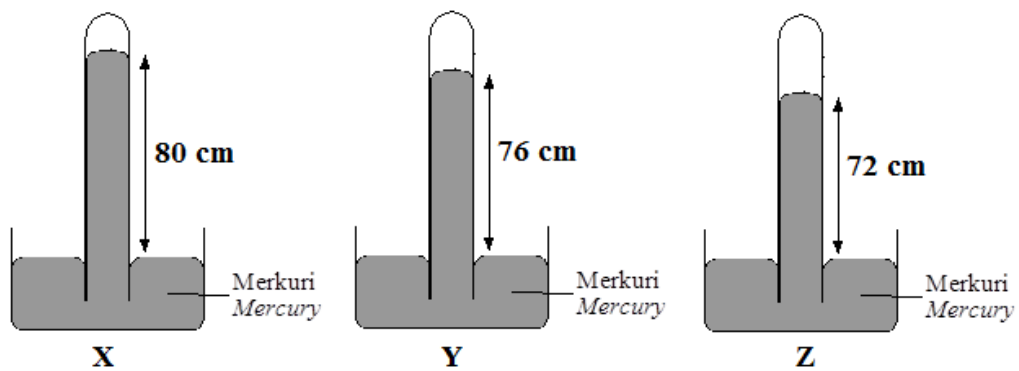

Rajah 15(b) / Diagram 15(b)

Rajah 15(a) menunjukkan tiga tempat berlainan altitud di P, Q dan R.
 Rajah 15(b) menunjukkan ketinggian turus merkuri dalam barometer serupa X, Y dan Z.
 Antara yang berikut, yang manakah benar mengenai ketinggian turus merkuri dengan kedudukan tempatnya?

Diagram 15(a) shows three locations of different altitudes at P, Q and R.

Diagram 15(b) shows the height of the mercury column in identical barometers X, Y and Z.

Which of the following is true about the height of the mercury column with the location?

	P	Q	R
A	Z	Y	X
B	Y	X	Z
C	X	Y	Z
D	X	Z	Y

27. Manakah antara berikut beroperasi berdasarkan Prinsip Pascal?

Which of the following operates due to the Pascal's Principle?

- A Mesin pengekstrak santan kelapa
Coconut milk extractor
- B Brek hidraulik
Hydraulic brake
- C Memicit ubat gigi
Squeezing toothpaste
- D Semua di atas
All of the above

28.



Rajah 16 / Diagram 16

Rajah 16 menunjukkan seorang lelaki dan sebuah rakit terapung di laut. Jisim lelaki dan rakit itu ialah 75 kg dan 54 kg masing-masing. Hitung isipadu rakit yang terendam dalam air laut. (Ketumpatan air laut ialah $1\,080\text{ kg m}^{-3}$, pecutan graviti, $g = 9.81\text{ m s}^{-2}$)

Diagram 16 shows a man and a raft floating in a sea. The mass of the man and the raft is 75 kg and 54 kg respectively. Calculate the volume of the raft that immersed in sea water. (The density of sea water is $1\,080\text{ kg m}^{-3}$, gravitational acceleration, $g = 9.81\text{ m s}^{-2}$)

- A 0.05 m^3
- B 0.10 m^3
- C 0.12 m^3
- D 1.19 m^3

29.

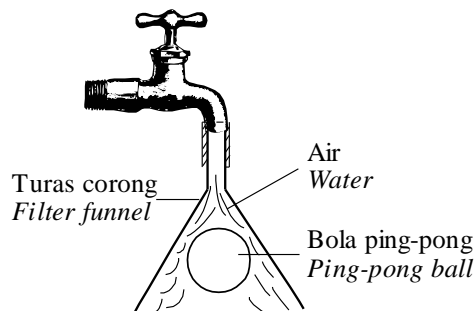

Rajah 17 / Diagram 17

Rajah 17 menunjukkan sebiji ping-pong tidak jatuh semasa air dialirkan. Prinsip yang manakah menerangkan situasi di atas?

Diagram 17 shows a ping-pong ball that does not fall when the water flows. Which of the following principle explains the above situation?

- A Prinsip Pascal
Pascal's Principle
- B Prinsip Keabadian Momentum
Principle of conservation of momentum
- C Prinsip Bernoulli
Bernoulli's Principle
- D Prinsip Archimedes
Archimedes' Principle

30. Rajah manakah yang menunjukkan corak medan elektrik yang betul?
Which diagram shows the **correct** electric field pattern?

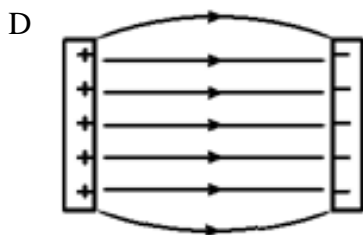
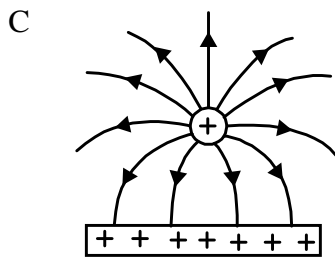
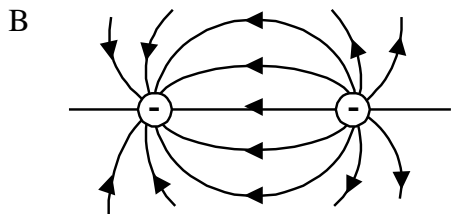
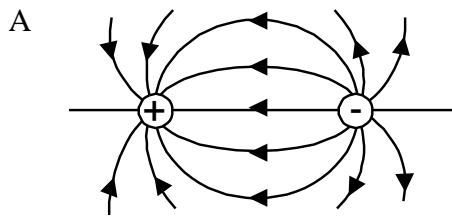

31. Seutas dawai mempunyai rintangan R . Apakah perubahan yang perlu dilakukan ke atas panjang dan diameter dawai tersebut untuk menghasilkan rintangan $2R$?
A piece of wire has a resistance of R . What are the changes need to be done on the length and the diameter of the wire to produce the resistance of $2R$?

	Panjang <i>Length</i>	Diameter <i>Diameter</i>
A	Digandakan <i>Doubled</i>	Digandakan <i>Doubled</i>
B	Diseparuhkan <i>Halved</i>	Digandakan <i>Doubled</i>
C	Digandakan <i>Doubled</i>	Diseparuhkan <i>Halved</i>
D	Diseparuhkan <i>Halved</i>	Diseparuhkan <i>Halved</i>

32. Rajah 18 menunjukkan satu litar yang mengandungi sel kering dan perintang R. Sel kering itu mempunyai rintangan dalam, r , dan daya gerak elektrik (d.g.e.) 1.5 V.
Diagram 18 shows a circuit containing a dry cell and resistor R. The dry cell has an internal resistance of r , and an electromotive force (e.m.f.) of 1.5 V.

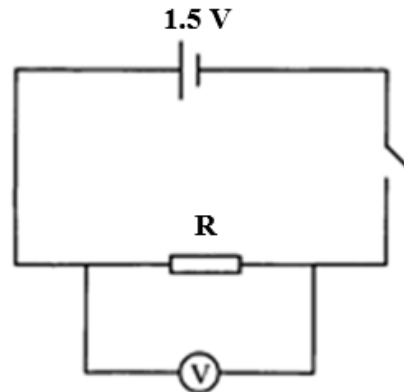

Rajah 18 / Diagram 18

Jika rintangan perintang tersebut adalah 13Ω dan bacaan voltmeter tersebut adalah 1.3 V, tentukan rintangan dalam bateri tersebut.

If the resistance of the resistor is 13Ω and the voltmeter reading is 1.3 V, determine the internal resistance of the battery.

- A 0.2Ω
 B 0.4Ω
 C 2.0Ω
 D 4.0Ω
33. Rajah 19 menunjukkan satu konduktor yang diletakkan dalam satu medan magnet.
Diagram 19 shows a conductor placed in a magnetic field.

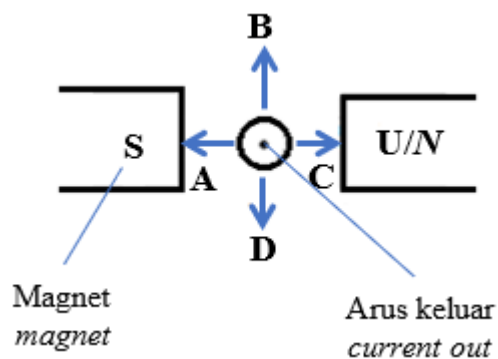

Rajah 19 / Diagram 19

Apabila arus mengalir keluar daripada kertas, arah manakah, A, B, C atau D, konduktor itu bergerak?

When current flows out of the paper, which direction, A, B, C or D, does the conductor move?

34. Rajah 20 menunjukkan satu model sistem penghantaran tenaga elektrik yang boleh dibina di dalam makmal. Model ini mengandungi satu stesen janakuasa yang menjana bekalan 12 V yang menghantar tenaga elektrik kepada pengguna menggunakan dawai penghantar dan transformer P, Q dan R.

Diagram 20 shows a model of an electrical energy transmission system that can be built in a laboratory. This model contains a power station that generates 12 V supply that transmits electrical energy to the consumer using transmitter wires and transformers P, Q and R.

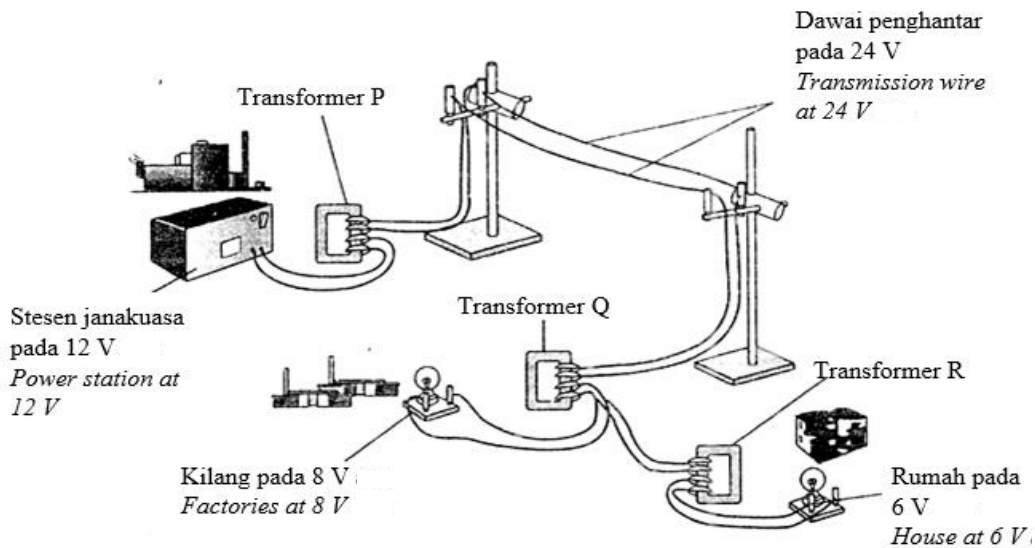

Rajah 20 / Diagram 20

Antara pernyataan-pernyataan berikut, yang manakah **benar**?

*Which of the following statements are **correct**?*

- I Transformer P adalah transformer injak naik
Transformer P is a step-up transformer
- II Transformer Q adalah transformer injak turun
Transformer Q is a step-down transformer
- III Bilangan lilitan gegelung sekunder transformer Q adalah sama dengan bilangan lilitan gegelung sekunder transformer R
The number of turns in secondary coil of transformer Q is the same as the number of turns in secondary coil of transformer R
- IV Jenis arus yang mengalir melalui sistem penghantaran di atas adalah arus ulang alik.
The type of current flow through the transmission system above is alternating current.

- A. I, II dan III sahaja
I, II and III only
- B. II, III dan IV sahaja
II, III and IV only
- C. I, II dan IV sahaja
I, II and IV only
- D. I, II, III dan IV
I, II, III and IV

35. Apakah yang dimaksudkan dengan pancaran termion?

What is the meaning of thermionic emission?

- A Pengaliran cas dalam suatu konduktor.
Flow of charge in a conductor.
- B Pemancaran elektron bebas daripada permukaan logam yang dipanaskan.
Emission of free electrons from a heated metal surface.
- C Alur elektron berkelajuan tinggi dalam vakum.
High speed electron beam in a vacuum.

36. Rajah 21 menunjukkan litar suis automatik untuk menyalakan mentol pada waktu malam.

Diagram 21 shows an automatic switch circuit for lighting a bulb at night.

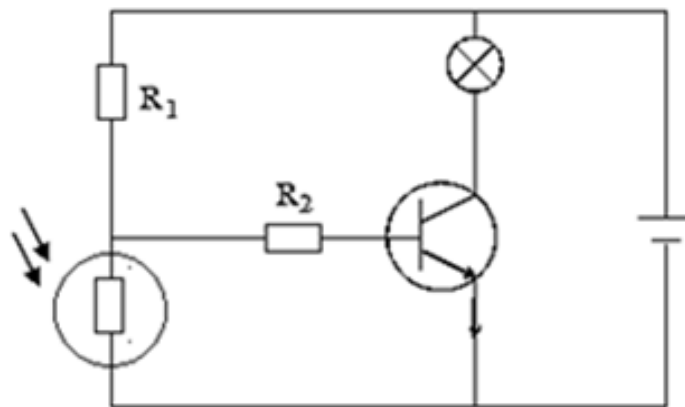

Rajah 21 / Diagram 21

Fungsi R_1 dan R_2 ialah

The functions of R_1 and R_2 are

	R_1	R_2
A	Menghadkan arus tapak <i>Limiting the base current</i>	Menghadkan arus pengumpul <i>Limiting the collector current</i>
B	Sebagai pembahagi voltan <i>As a potential divider</i>	Menghadkan arus tapak <i>Limiting the base current</i>
C	Sebagai pembahagi voltan <i>As a potential divider</i>	Menghadkan arus pengumpul <i>Limiting the collector current</i>
D	Menghadkan arus tapak <i>Limiting the base current</i>	Sebagai pembahagi voltan <i>As a potential divider</i>

37. Rajah 22 menunjukkan lengkung pereputan bagi tiga radioisotop yang berbeza.
Diagram 22 shows the decay curves for three different radioisotopes.

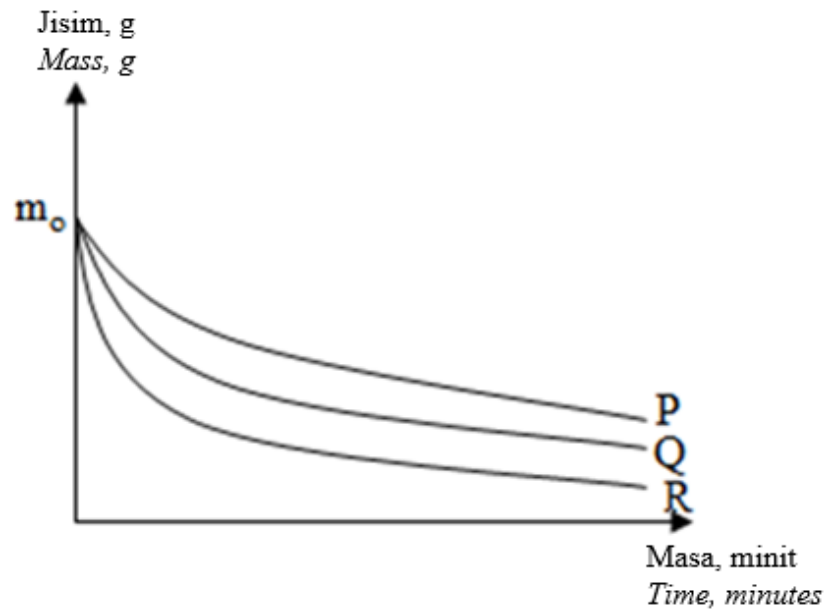

Rajah 22 / Diagram 22

Antara berikut, yang manakah menunjukkan perbandingan separuh hayat yang betul bagi radioisotop P, Q dan R?

Which of the following shows the correct comparison of the half-life of radioisotope P, Q and R?

- A $P > Q > R$
 B $Q > R > P$
 C $R > P > Q$
 D $R > Q > P$
38. Pelakuran nuklear adalah
Nuclear fusion is
- A penggabungan dua nukleus ringan untuk membentuk satu nukleus lebih berat.
fusion of two lighter nuclei to form one heavier nucleus.
- B kehilangan tenaga dalam tindak balas nuklear.
loss of energy in a nuclear reaction.
- C kehilangan jisim atom tindak balas nuklear.
loss of atomic mass of a nuclear reaction.
- D pembelahan satu nukleus berat kepada dua nukleus lebih ringan.
fission of one heavy nucleus into two lighter nuclei

39. Rajah 23 menunjukkan rumus yang telah diperkenalkan oleh Louis de Broglie untuk menyatakan hubungan antara momentum suatu zarah, p dengan panjang gelombang λ .
Diagram 23 shows the formula introduced by Louis de Broglie to express the relationship between the momentum of a particle, p and the wavelength λ .

$$\lambda = \frac{h}{p}$$

$h =$ pemalar Planck
Planck's constant

Rajah 23 / Diagram 23

Berdasarkan rumus tersebut, apakah yang boleh disimpulkan mengenai hubungan antara momentum zarah p dan panjang gelombang λ .

Based on the formula, what can be concluded about the relationship between the momentum of a particle p and the wavelength λ .

- A Momentum zarah berkadar langsung dengan panjang gelombang bagi zarah.
The momentum of a particle is directly proportional to the wavelength of the particle.
- B Panjang gelombang zarah berkadar songsang dengan momentum zarah.
The wavelength of the particle is inversely proportional to the momentum of the particle.
- C Semakin bertambah panjang gelombang zarah, semakin bertambah momentum zarah.
The longer the wavelength of the particle, the greater the momentum of the particle.
- D Panjang gelombang zarah berkurang secara linear dengan momentum zarah.
The wavelength of the particle decreases linearly with the momentum of the particle.
40. Cahaya hijau yang berfrekuensi 5.45×10^{14} Hz disinarkan ke atas permukaan logam cesium yang bersih. Berapakah tenaga kinetik maksimum fotoelektron yang terpancar keluar?
 [Fungsi kerja cesium = 3.43×10^{-19} J, pemalar Planck = 6.63×10^{-34} J s]
Green light with a frequency of 5.45×10^{14} Hz is irradiated on a clean caesium metal surface. What is the maximum kinetic energy of the photoelectron emitted out?
 [Working function of caesium = 3.43×10^{-19} J, Planck constant = 6.63×10^{-34} J s]
- A 1.83×10^{-20} J
- B 3.61×10^{-20} J
- C 1.83×10^{-19} J
- D 3.61×10^{-19} J

**SKEMA JAWAPAN
PRAKTIS FIZIK 4531/1
SET 2**

1	B	11	B	21	C	31	D
2	B	12	D	22	B	32	C
3	C	13	C	23	C	33	D
4	A	14	D	24	A	34	C
5	A	15	B	25	B	35	B
6	A	16	A	26	A	36	B
7	D	17	B	27	D	37	A
8	C	18	C	28	C	38	A
9	B	19	C	29	C	39	B
10	D	20	D	30	D	40	A

LAMPIRAN

(Untuk rujukan guru)

SAMPEL JADUAL SPESIFIKASI UJIAN (JSU) PRAKTIS FIZIK 4531/1: SET 2

Chapter	Sub-chapter	Remembering			Understanding			Applying			Analyzing			Total
		E	M	H	E	M	H	E	M	H	E	M	H	
1. Measurement	1.1 Physical Quantity				X									1
	1.2 Scientific Investigation													0
2. Force and Motion I	2.1 Linear Motion													0
	2.2 Linear Motion graphs											X		1
	2.3 Free Fall Motion	X												1
	2.4 Inertia	X												1
	2.5 Momentm				X									1
	2.6 Force													0
	2.7 Impulse and Impulsive Force							X						1
	2.8 Weight													0
3. Gravitation	3.1 Newton's Law of Universal Gravitation													0
	3.2 Kepler's Law							X						1
	3.3 Man-made Satellites									X				1
4. Heat	4.1 Thermal Equilibrium				X									1
	4.2 Specific Heat Capacity													0
	4.3 Specific Latent Heat							X						1
	4.4 gas Laws					X								1
5. Waves	5.1 Fundamentals of waves							X						1
	5.2 Damping and resonance				X									1
	5.3 Reflection of waves				X									1
	5.4 Refraction of waves													0
	5.5 Diffraction of Waves	X												1
	5.6 Interference of Waves								X					1
	5.7 Electromagnetic Waves													0
Chapter	Sub-chapter	Knowledge			Understanding			Application			Analysis			Total
		E	M	H	E	M	H	E	M	H	E	M	H	
6. Light and Optics	6.1 Refraction of Waves													0
	6.2 Total Internal Reflection	X												1
	6.3 Image Formation by Lenses													0
	6.4 Thin Lens Formula											X		1
	6.5 Optical Instruments				X									1
	6.6 Image Formation by spherical mirrors					X								1
7. Force and Motion II	7.1 Resultant Force					X								1
	7.2 Resolution of Forces							X						1
	7.3 Forces in Equilibrium	X												1
	7.4 Elasticity											X		1
8. Pressure	8.1 Pressure in Liquids							X						1
	8.2 Atmospheric Pressure									X				1
	8.3 Gas Pressure													0
	8.4 Pascal's Principle				X									1
	8.5 Archimedes' Principle								X					1
	8.6 Bernoulli's Principle				X									1
9. Electricity	9.1 Current and Potential Difference	X												1
	9.2 Resistance											X		1
	9.3 Electromotive Force and Internal Resistance							X						1
	9.4 Electrical Energy and Power													0
10. Electromagnetism	10.1 Force on a Current-carrying Conductor in a magnetic Field				X									1
	10.2 Electromagnetic Induction												X	0
	10.3 Transformer													1
11. Electronics	11.1 Electron	X												1
	11.2 Semiconductor Diode													0
	11.3 Transistor						X							1
Chapter	Sub-chapter	Knowledge			Understanding			Application			Analysis			Total
		E	M	H	E	M	H	E	M	H	E	M	H	
12. Nuclear Physics	12.1 Radioactive Decay											X		1
	12.2 Nuclear Energy		X											1
13. Quantum Physics	13.1 Quantum theory of Light				X									1
	13.2 Photoelectric Effect													0
	13.3 Eirtein's Photoelectric Theory							X						1
Total		7	1	0	10	3	1	1	7	2	2	1	5	40
Ratio of E:M:H		20	12	8										
Level of Difficulty	E : Easy M : Medium H : Hard													